

CABLE TRAYS FOR INDUSTRIAL INFRASTRUCTURES
AND BUILDINGS

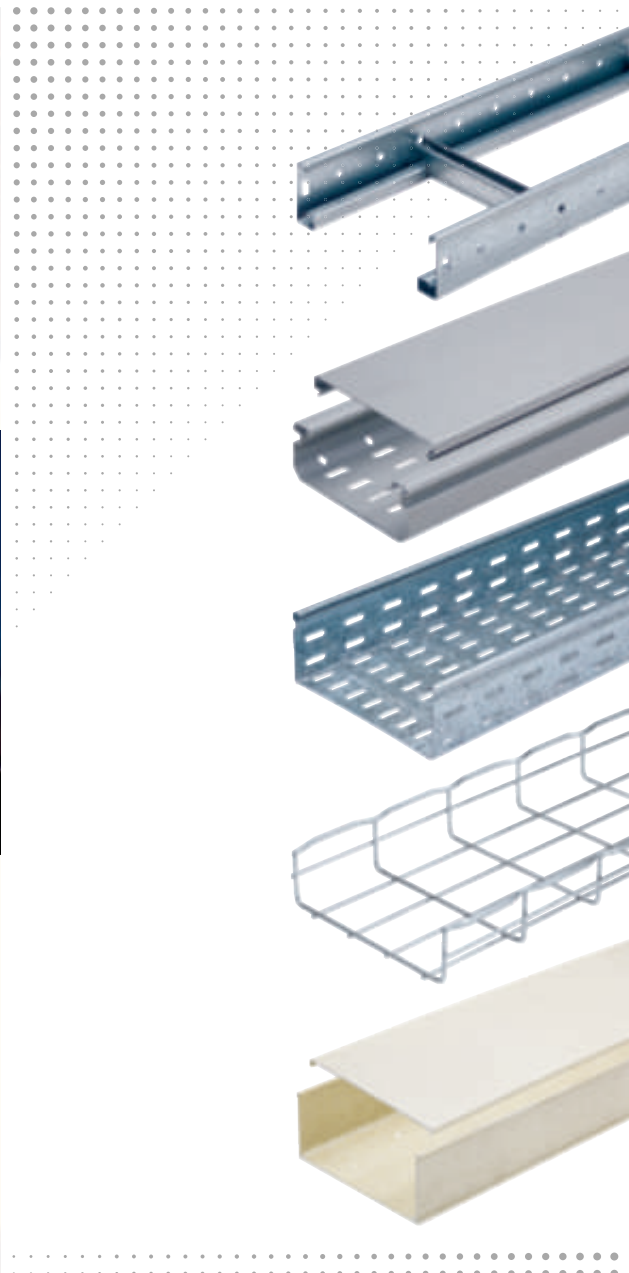

FIRST-CLASS SOLUTIONS
FOR YOUR LARGE-SCALE PROJECTS

THE GLOBAL SPECIALIST IN ELECTRICAL
AND DIGITAL BUILDING INFRASTRUCTURES



DO YOU HAVE A LARGE-SCALE PROJECT?

"OUR HIGH-PERFORMANCE SOLUTIONS HAVE BEEN DEVELOPED FOR YOUR LARGEST SITES AND YOUR MOST COMPLEX PROJECTS."

For more than sixty years, the mission of the **Legrand Group** has been to design, develop and sell both simple and innovative electrical and digital systems.

Systems to provide better communication, protect electrical installations,

carry power, increase safety and improve comfort in buildings.



Customised solutions using strong, cleverly-designed cable trays.

Airports, road and rail tunnels, viaducts, power generation plants, seawater desalination units, purification stations, offshore and onshore oil and gas installations...



With the **Legrand Group** you can be assured of high performance and clever design for your most complex projects.

The Legrand group's **development strategy** and **innovative strength** in the **cable tray** market have been established to provide an effective

response to your **professional requirements** and to **market demands**.

Legrand is established in **over 80 countries and distributes its products in around 180 countries** worldwide, offering a comprehensive range

of products and systems for electrical and digital infrastructures in residential, commercial and industrial buildings.

A WORLDWIDE REFERENCE, LEGRAND HAS ESTABLISHED ITSELF AS A MARKET LEADER!

Production sites close to where consumption takes place ensure **top quality service** and **certification**.



Production sites specialising in the manufacture of cable trays:

Brazil, China, France, Italy, Mexico, Russia, Saudi Arabia, The Netherlands, United Kingdom, United States

"THE STRENGTH OF A LEADER FOR YOUR LARGEST PROJECTS"

- **User interface**
Switches, power sockets, VDI sockets...
- **Energy distribution**
Distribution panels, circuit breakers...
- **Building systems**
Lighting control, security systems...
- **Cable management**
Trunking, floor boxes...
- **Digital infrastructure**
Enclosures, patch panels, RJ45 sockets...

- **UPS**
Uninterruptible power supply devices
- **Installation components**
Tubes, ducts, extensions...

Legrand stands out with the breadth of its range, available worldwide.

A SPECIALIST TEAM AT YOUR SIDE

Our teams of experts are **ready** to help you **design** your largest projects, however complex, providing you with the most

suitable solutions and working closely with you throughout the project.

EVERY STEP
IS COVERED
IN METICULOUS
DETAIL:

- **Completion of the technical study**

Based on the specifications provided

- **Provision of files**

Provision of BIM compatible files for integration in 3D design software (such as Aeva, Intergraph, etc.)

- **Design and manufacture of "customised" products**

matching the technical description provided

- **On-site support**

To provide advice and train the teams to install the products

- **Tests and provision of certificates**

PROXIMITY
RESPONSIVENESS
COMPETITIVENESS



Excellent logistics, the capacity to produce large quantities and compliance with delivery deadlines all make the Legrand Group the **leader in this sector**.

**60 YEARS OF
EXPERTISE**
in cable routing

Reliable, certified products that are ideal for all technical requirements, with no limitations, worldwide, whatever the standard.

RECOGNISED
CERTIFICATIONS FOR
A WELL-ESTABLISHED,
INNOVATIVE COMPANY.



COMMITTED TO A SUSTAINABLE DEVELOPMENT POLICY

Legrand, together with its customers and partners, has been committed to a **process of continuous improvement** for many years, to ensure the long-term

and responsible growth of its business. The Group thus intends to respond to the **environmental, economic and social challenges** of today and the future.

OUR REFERENCE PROJECTS:

■ Oil & Gas

- CIMC RAFFLES oil platforms
CHINA
Cablofil steel wire cable tray
- Gaz de France North Sea oil platforms
NETHERLANDS & BELGIUM
Swifts cable ladder
- Satorp Saudi Aramco/TOTAL Jubail Refinery **KSA**
Cablofil steel wire cable tray & Seico cable ladder
- Technip Ras Laffan Olefin plant
QATAR *Seico cable ladder*
- Umm Lulu Phase 1 Development Project **ADMA/OPCO - UAE**
Swifts metal cable tray & cable ladder

■ Infrastructures

- Jeddah airport **KSA**
P31 metal cable tray
- S6 Niklasdorf Tunnel
AUSTRIA
P31 metal cable tray
- Macau Ferry Terminal
HONG KONG
Isiplast PVC cable tray
- Algiers Metro **ALGERIA**
GL04 cable ladder, Cablofil steel wire cable tray & Isiplast PVC cable tray
- SNCF Bordeaux sound abatement wall
FRANCE
Polysis cable tray

■ Industry

- OSRAM Opto Semiconductors Co. Ltd Factory **CHINA**
Cablofil steel wire cable tray
- Abu Dhabi Sewerage Services Company (ADSSC) **ABU DHABI**
Swifts metal cable tray & cable ladder
- Sweihan Wastewater Treatment Plant **AL SAAD - UAE**
Swifts metal cable tray & cable ladder
- OCP Samsung project **MOROCCO**
Isiplast PVC cable tray

The various ranges of **cable trays** have been specially designed for your specific large-scale projects.

First-class solutions providing you with top quality to meet the requirements of your projects.

OUR SOLUTIONS

CABLOFIL STEEL WIRE CABLE TRAYS

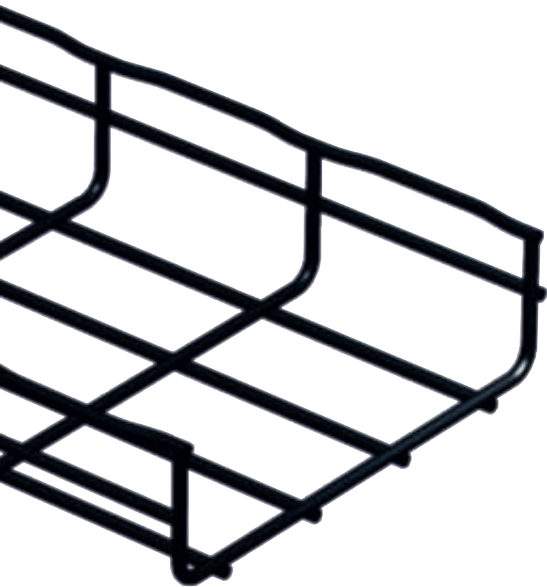

In the same range:

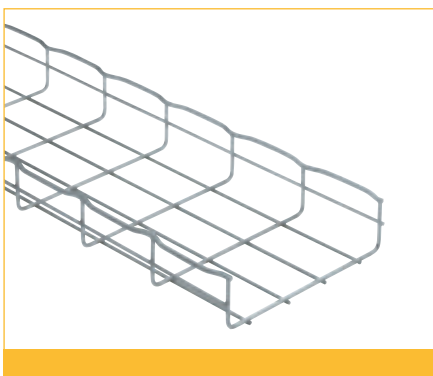

- **Flexibility of routing**
Numerous possible configurations
- **Speed of installation**
Screw-free quick couplers
- **Strength and durability**
Corrosion-resistance due to various surface treatments
- **Exclusive safety edge**
Safe-T-Edge
T-welded so there are no sharp edges, and to avoid accidents during installation
- **Open structure**
Visual inspection and maintenance of cables, minimum temperature rise of cables, dust retention minimised, no water retention if a fire extinguishing system is triggered

MAXIMUM FLEXIBILITY
GUARANTEED FIRE RESISTANCE

Cablofil the Legrand cable tray with the most certifications has successfully passed all the laboratory tests and complies with the requirements of the standards (UL, IEC EN 61537).
It is certified E 30/E 90 in line with DIN 4102-12 standard and CSIRO.

An **extensive range of finishes** to match the requirements of the installation:

The EZ+ version (additional coating applied over zinc electroplating - standard EN ISO 2081) is particularly suitable for corrosive

environments such as road tunnels, airports or power generation facilities, guaranteeing excellent resistance over time.

CABLE TRAYS FOR ALL ENVIRONMENTS



P31 & SEICO METAL CABLE TRAYS



- **Available in solid or perforated sheet metal and in various versions**
 From "light" to "extra heavy duty" depending on the requirements of the site
- **Excellent mechanical strength and rigidity**
 Safety edge and ridge for clipping on covers
- **Staggered perforations**
 Can be attached to supports without drilling (for the perforated sheet metal version)
- **Clip-on covers, coupling systems and screw-free fixing**
 Easier installation and adaptation to all configurations (for the perforated sheet metal version)

CLEVER DESIGN
HIGH QUALITY
EXCELLENT
FIRE RESISTANCE

Optimal fireproof structure.

The P31 perforated sheet metal cable tray guarantees very high fire resistance.

It is certified E 30/E 90 in line with DIN 4102-12 standard.

In the same range:



Our other cable tray families:

P.06 ■ Swifts & Seico cable ladder

P.07 ■ Metal support systems

P.08 ■ Polysis composite cable tray

P.09 ■ PVC cable tray

OUR SOLUTIONS

SWIFTS & SEICO CABLE TRAYS

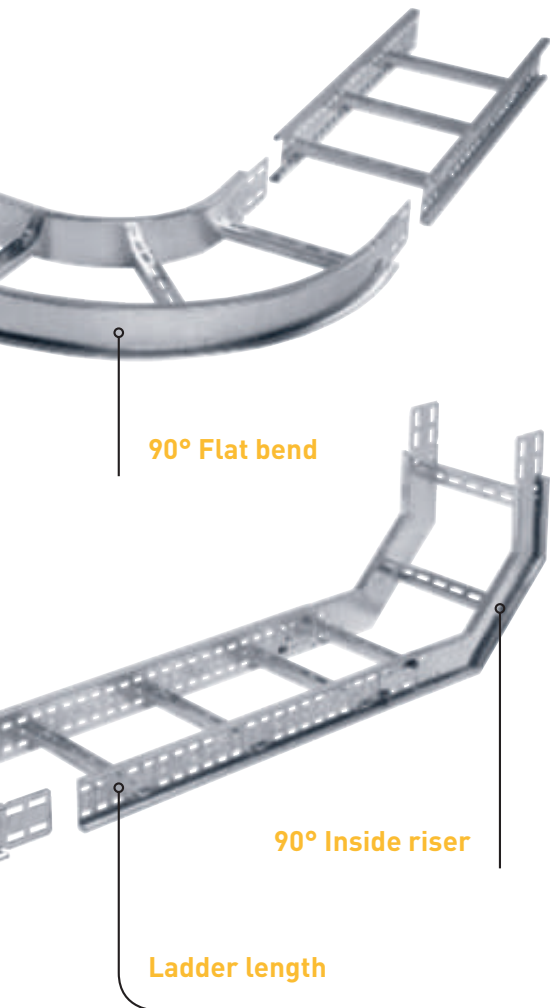

- **Special support system**

Numerous configurations possible with the routing accessories

- **Quick to install and lower equipment costs**

Integrated coupling system on all risers, joining kits, quick bolt-nut fixing...

- **Rolled edges**

Increased strength and safety when fitting (no sharp edges)

- **Open structure**

Visual inspection and maintenance of cables, minimum temperature rise of cables, dust retention minimised, no water retention if a fire extinguishing system is triggered

The range is available in widths of up to 900 mm.

UNFAILING STRENGTH

Increased capacity for heavy loads up to 100 kg/m with a 6 m span

Can carry a very large number of cables: a solution ideal for large sites.

STRENGTH
SAFETY
AND ADAPTABILITY



METAL SUPPORT SYSTEMS



A complete, functional range of accessories for installing cable trays

In the same range:



- **Flexibility and compatibility**
A single range for all metal cable trays (wire, sheet metal or cable ladder)
- **Appropriate solutions**
According to the fixing type: wall, ceiling, floor...
- **Quick and easy to install**
Automatic assembly systems available on many of the supports in the range

AN EXTENSIVE RANGE OF SOLUTIONS SUITABLE FOR ALL APPLICATIONS

Maximum safety.

Various surface treatments available according to the degree of corrosion of the location.

Products tested in line with the recommendations of standard IEC/EN 61537.

Our other cable tray families:

P.04 ■ Cablofil steel wire cable trays

P.08 ■ Polysis composite cable tray

P.05 ■ P31 & Seico metal cable trays

P.09 ■ PVC cable tray

OUR SOLUTIONS

POLYSIS COMPOSITE CABLE TRAYS

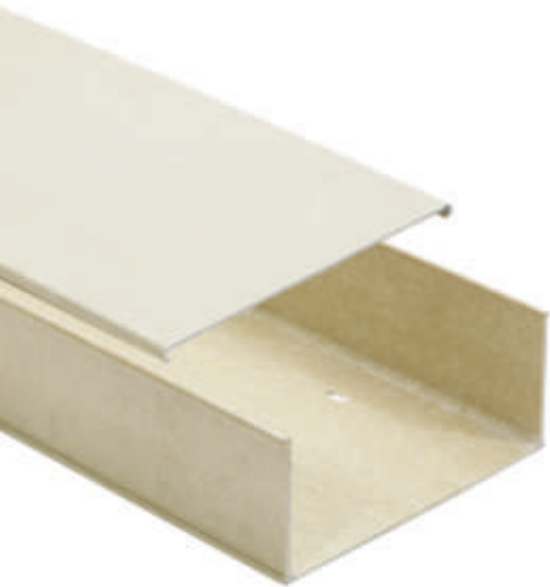

■ Exceptional strength

The Polysis GRP range is made of a pultruded material which combines fibre glass and a thermosetting resin matrix, giving the cable trays exceptional mechanical strength, and resistance to corrosion, UV and chemical agents

■ Optimum fire resistance

Non-flammable, self-extinguishing, flame retardant material (Class M1)

■ Impact resistance

High resistance up to 20 J, depending on the version

■ Easy, low-cost installation

EXCELLENT CORROSION & FIRE RESISTANCE

Guaranteed safety.

Excellent electrical and thermal insulation. Operating temperature range: -20° to +130°C.

Halogen-free material. Conforms to the RoHS directive.

Ideal solution for industrial configurations in corrosive environments where a high degree of mechanical strength is essential: structures and tunnels subject to fire/smoke requirements.

The manufacturing method used makes this composite material corrosion-resistant and gives it excellent mechanical strength, guaranteeing the durability of installations.

THE IDEAL CHOICE FOR DAMP AND CORROSIVE ENVIRONMENTS



PVC CABLE TRAYS



- **Excellent resistance**

To damp, corrosion and chemical agents

- **Non-flammable, self-extinguishing**

Flame retardant and good fire resistance (Class M1)

- **Impact resistance**

High resistance up to 20 J, depending on the version

- **Available in standard or reinforced version**

With solid or perforated base

- **Easy to install**

Lightweight for easy handling and transport, and easy to cut or perforate. Routing and fixing accessories for adaptation to complex configurations

- **Eco-friendly**

PVC is 100% recyclable

RESISTANT
TO DAMP
& CORROSION
NO THERMAL STRESS

The PVC cable tray does not conduct electricity. There is therefore no earthing.

Operating temperature range: -20° to +60°C.

Conforms to the RoHS directive.

Our other cable tray families:

P.04 ■ Cablofil steel wire cable trays





P.05 ■ P31 & Seico metal cable trays

P.06 ■ Swifts & Seico cable ladder

P.07 ■ Metal support systems



FOLLOW US ALSO ON

-  www.legrand.com
-  www.youtube.com/user/Legrand
-  www.facebook.com/Legrand
-  twitter.com/Legrand
-  pinterest.com/legrandgroup

EX215037 - July 2015



Head Office and International Department

128, av. du Maréchal-de-Lattre-de-Tassigny
87045 Limoges Cedex - France

☎ : + 33 (0) 5 55 06 87 87

Fax : + 33 (0) 5 55 06 74 55